

ECO 610: Lecture 7

Perfectly Competitive Markets

Perfectly Competitive Markets: Outline

- Goal: understanding firm and market supply in competitive markets
- Characteristics of perfectly competitive industries
- Short-run production decision of a perfectly competitive firm
- Short-run market supply and equilibrium in a perfectly competitive market
- Long-run adjustments and equilibrium in a perfectly competitive market

A taxonomy of market structures

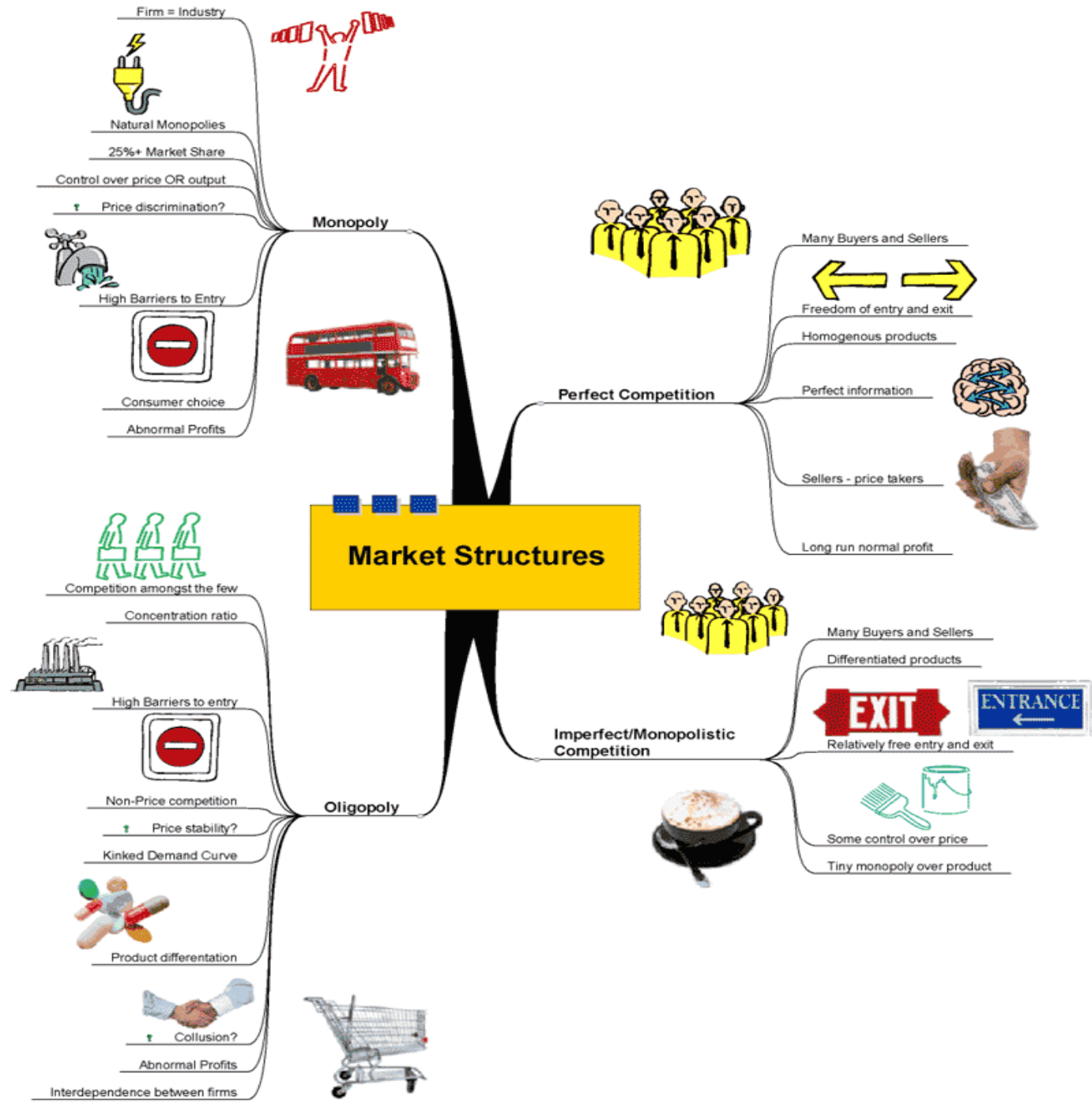

Characteristics of a perfectly competitive market

- Large number of small, independent sellers
- Large number of small, independent buyers
- Homogeneous product
- Insignificant barriers to entry and exit
- Perfect information available to buyers and sellers
- Examples? Alligator farming?

Can you really farm these things?



Short-run production decision of a perfectly competitive firm

- Imagine that you are a commodity market analyst for a major fashion house:
<http://search.proquest.com.ezproxy.uky.edu/docview/399057549?accountid=11836>
- The CEO comes to you and asks where you think alligator skin prices are going, because she wants to add a line of alligator handbags, luggage, and cowboy boots.
<http://www.ralphlauren.com/product/index.jsp?productId=3107868>
- You say let me do some research and get back to you on that.
- What analytical framework do you use to figure out what is going on now in the alligator market and where things are headed?

The usefulness of abstract models

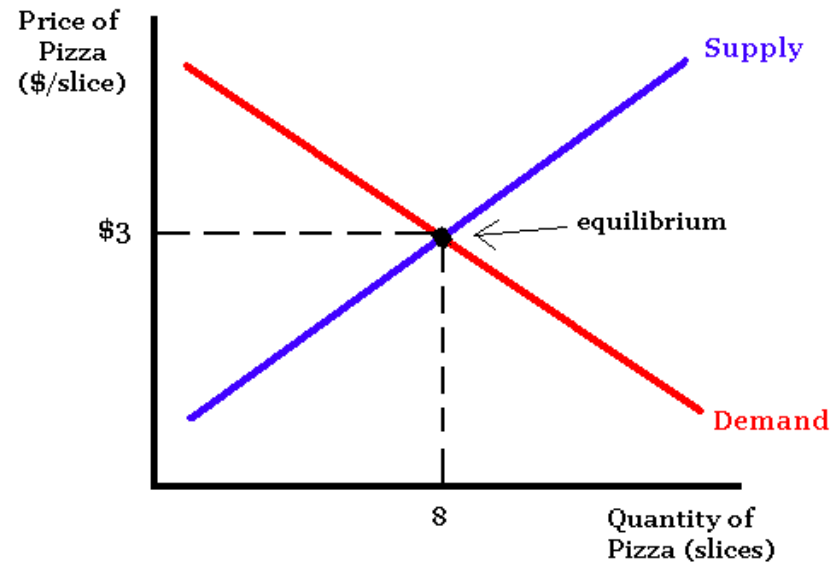
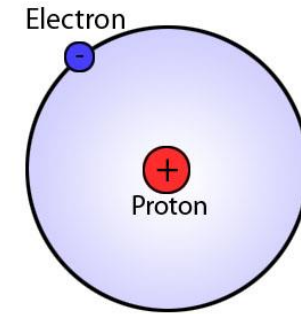
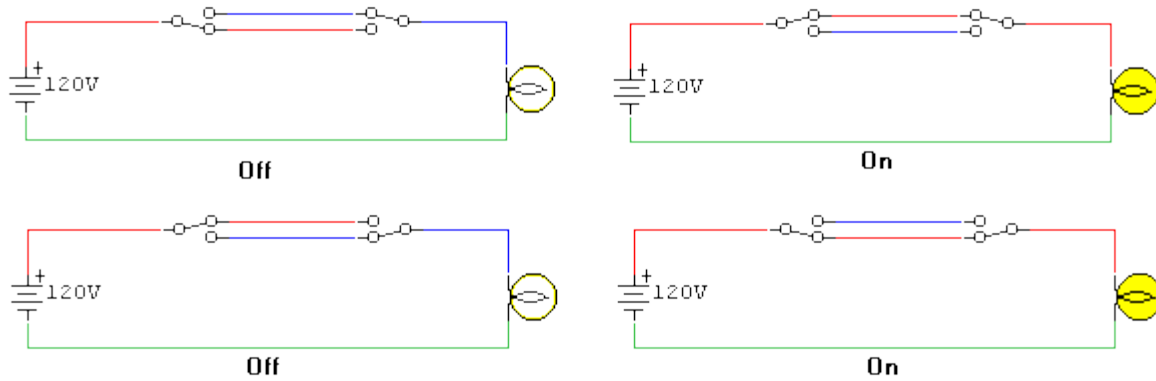

Modeling the firm's supply decision

- To understand how price and output get determined in both the short run and long run in a competitive industry, let's ask and answer a series of questions:
 - How is the price of alligators determined?
 - What does the demand curve facing each individual alligator farmer look like?
 - What output will maximize profit for the farmer in the short run?
 - What happens to the farmer's optimal output as market price changes?
 - What does the farmer's short-run supply curve look like?
 - What does the short-run market supply curve for alligators look like, given information on individual farmers' supply curves?

➤ How is the price of alligators determined?

- Market demand and supply. Market demand represents the collective decisions of all alligator buyers. We are building towards understanding how market supply is determined.

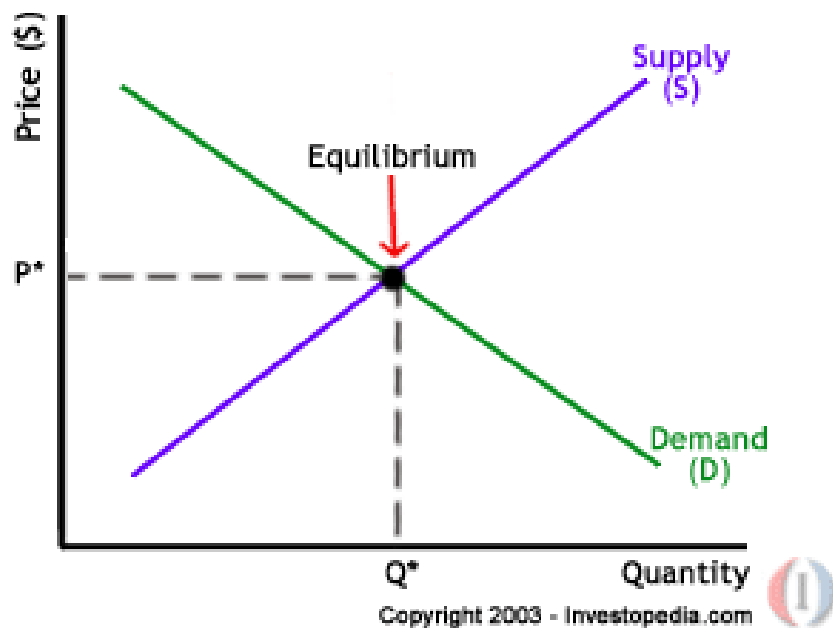

What is P^* in 1987 in the market for alligators?

<http://ezproxy.uky.edu/login?url=http://search.proquest.com/docview/398158016?accountid=11836>

➤ What does the demand curve facing each individual alligator farmer look like?

- If each producer is small relative to the market, what impact will any one producer's output decision have on market price?
- What is the relevant range of output for an individual alligator farmer?
- What is industry output?
- What happens to market price if an individual alligator farmer withholds all his gators from the market in a given year?
- What happens to market price if that farmer produces and sells as many as he can in a given year?
- We say that a firm in a perfectly competitive industry is a **Price Taker**, because the firm's demand curve is perfectly elastic at the market price.

Demand Curve of a Perfectly Competitive Firm

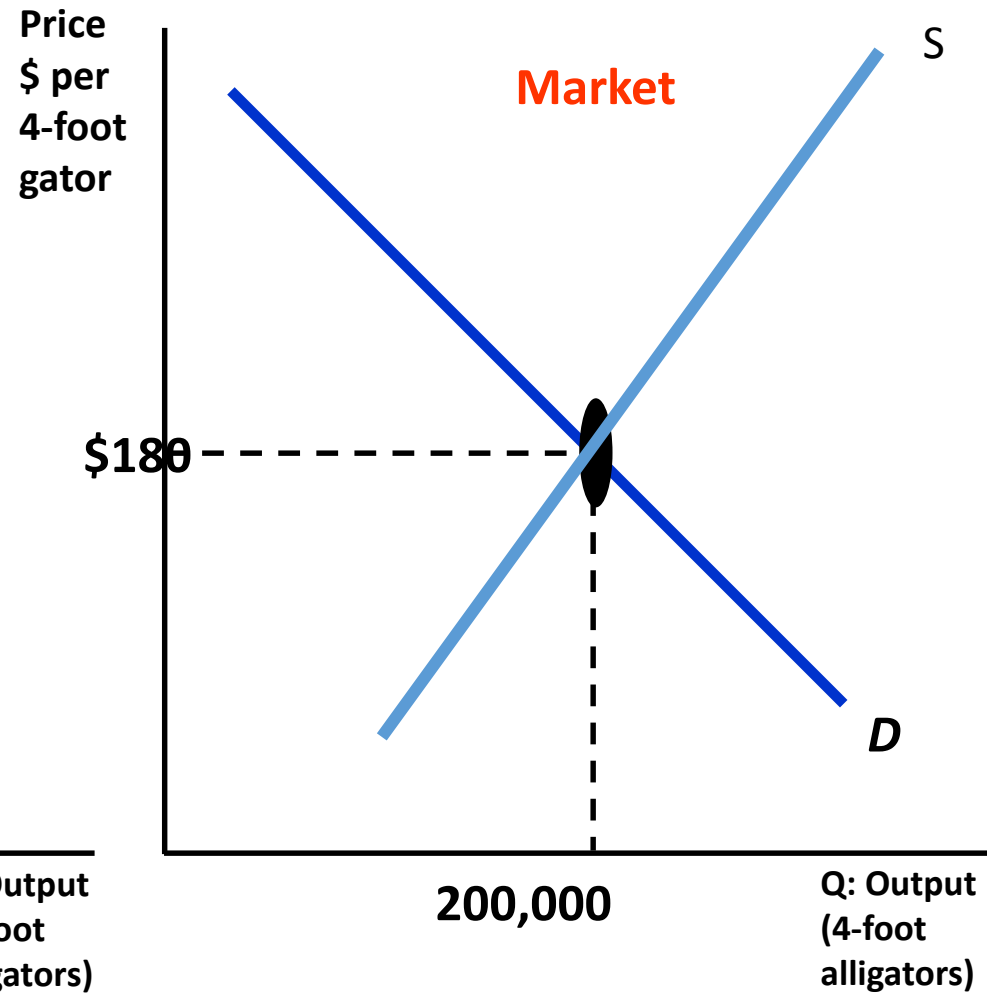
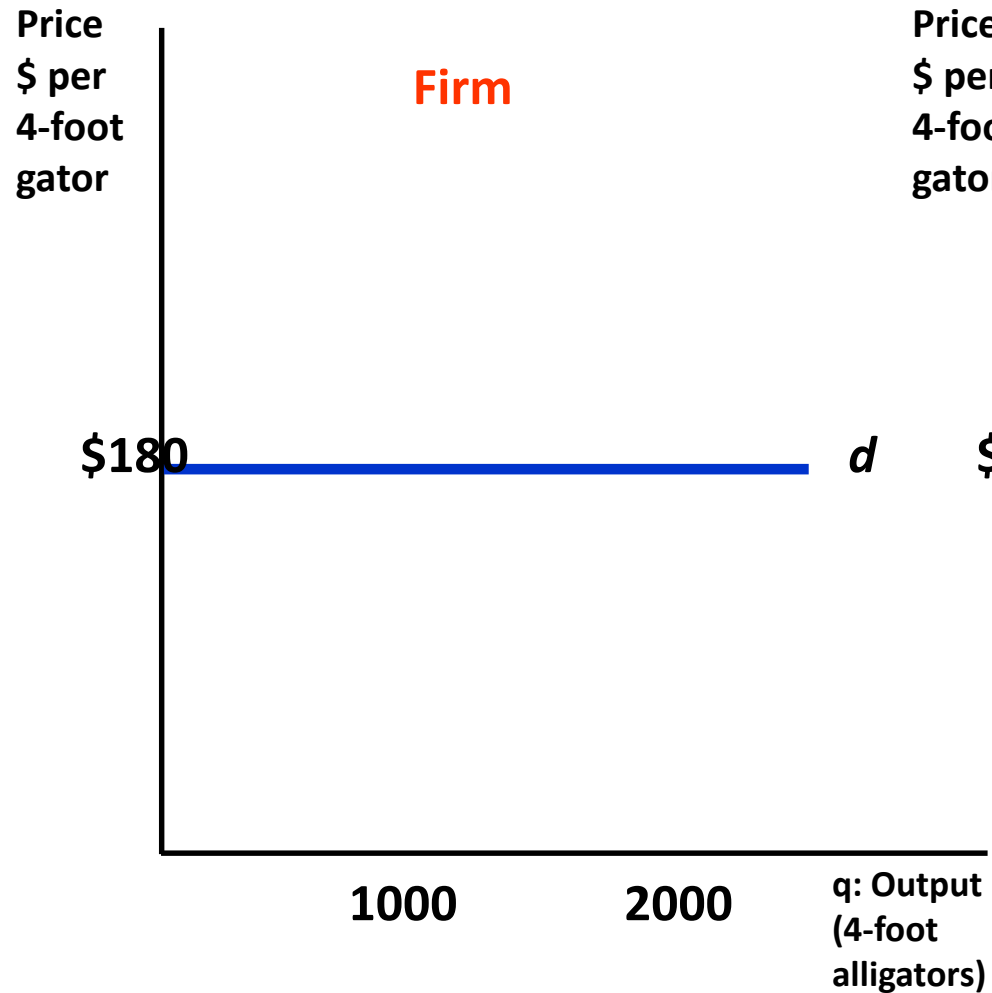

➤ What output will maximize profit for the firm in the short run? The shutdown rule

- First decision: produce $q = 0$ or produce $q > 0$ in the short run?
- What does producing $q = 0$ in the short run [i.e. shut down] look like? What does producing $q = 0$ in the long run [i.e. go out of business] look like?
- <http://abcnews.go.com/WNT/video/wasting-strawberry-fields-10220551>
- How to decide whether to shut down or produce a positive output?
- $\pi = TR - TC = TR - TVC - TFC$
- If $q = 0$, then $TR = 0$ and $TVC = 0$, so $\pi = -TFC$; i.e. your losses equal your fixed costs
- If $q > 0$, then $\pi = TR - TVC - TFC$
- So, if $[TR - TVC] > 0$, you are better off producing $q > 0$. If $TR < TVC$, you are better off shutting down in the short run.
- Alternatively, if $TR/q < TVC/q$, i.e. **if $P < AVC$, then shut down in the short run.**

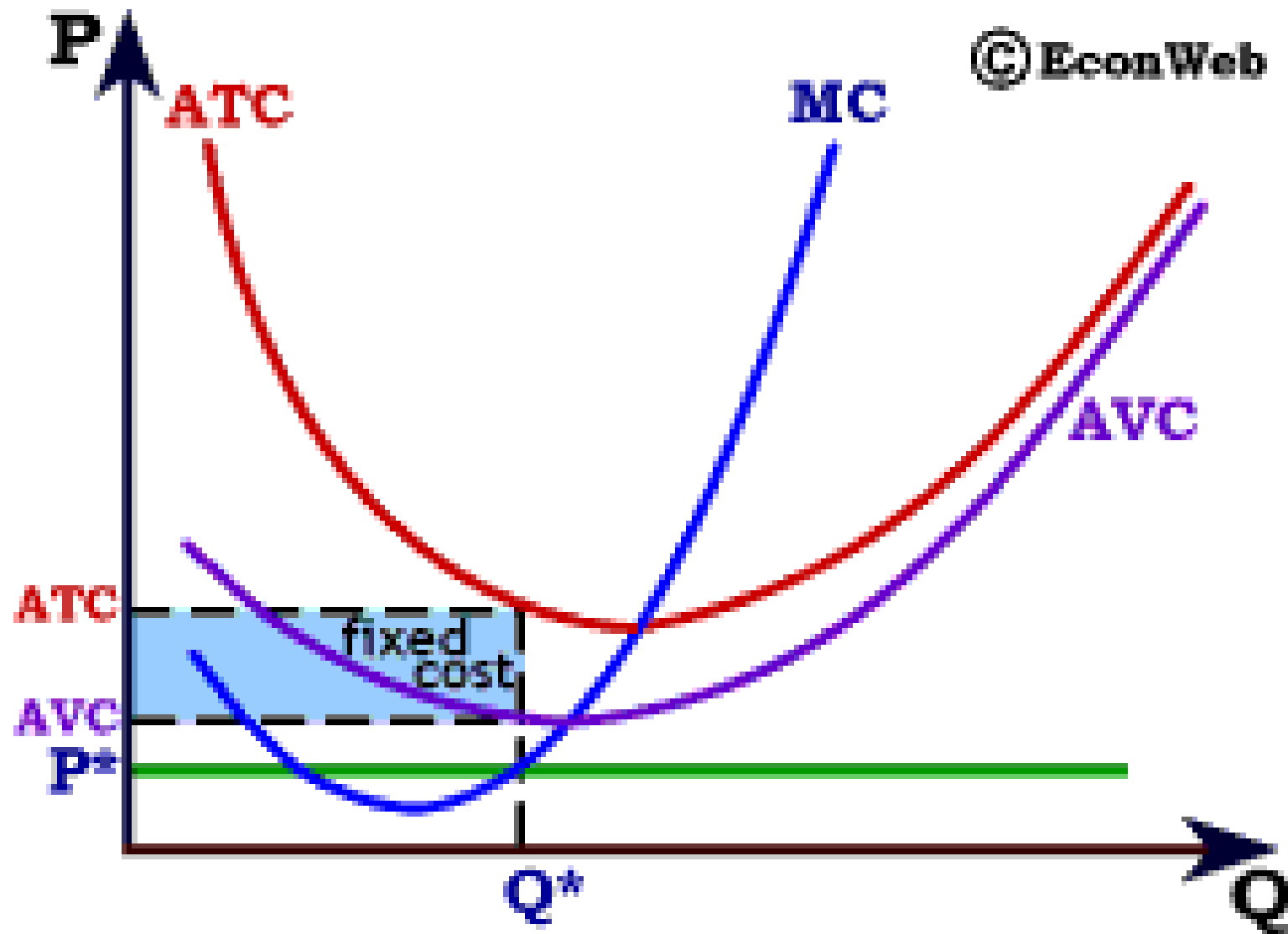

- What output will maximize profit for the firm in the short run? Producing a positive rate of output
- If $P_{\text{Mkt}} > \min \text{AVC}$ such that producing a $q > 0$ is optimal, what q will maximize profit for the firm in the short run?
 - Expand output as long as producing and selling another unit adds more to total revenue than it does to total cost.
 - In other words, expand output up to point where $\text{MR} = \text{MC}$.
 - [Refer to diagram drawn on board for typical alligator farmer, with AVC and MC diagrams included.]
 - What is marginal revenue for a perfectly competitive firm? $\text{MR} = \Delta \text{TR} / \Delta q$.
 - As the firm expands output, does it have to lower price to sell more output? No, hence $\text{MR} = \text{P} = \text{d}$.

➤ What does the firm's short-run supply curve look like?

- As market price varies from zero to \$200 per four-foot gator, what output will maximize profits (minimize losses) at each possible price?
- [Refer to diagram drawn on board for derivation of competitive firm's short-run supply curve]
- If $P_{Mkt} < \min AVC$, then $q^* = 0$, where q^* is the firm's profit-maximizing output.
- If $P_{Mkt} > \min AVC$, then producing q^* where $P_{Mkt} = MC$ will maximize short-run profits (minimize short-run losses) for the firm.
- Does the firm's short-run supply curve obey the Law of Supply?
- What is the logic of the economic behavior suggested by the firm's short-run supply curve that we have just derived?

A Firm's Short-Run Supply Curve

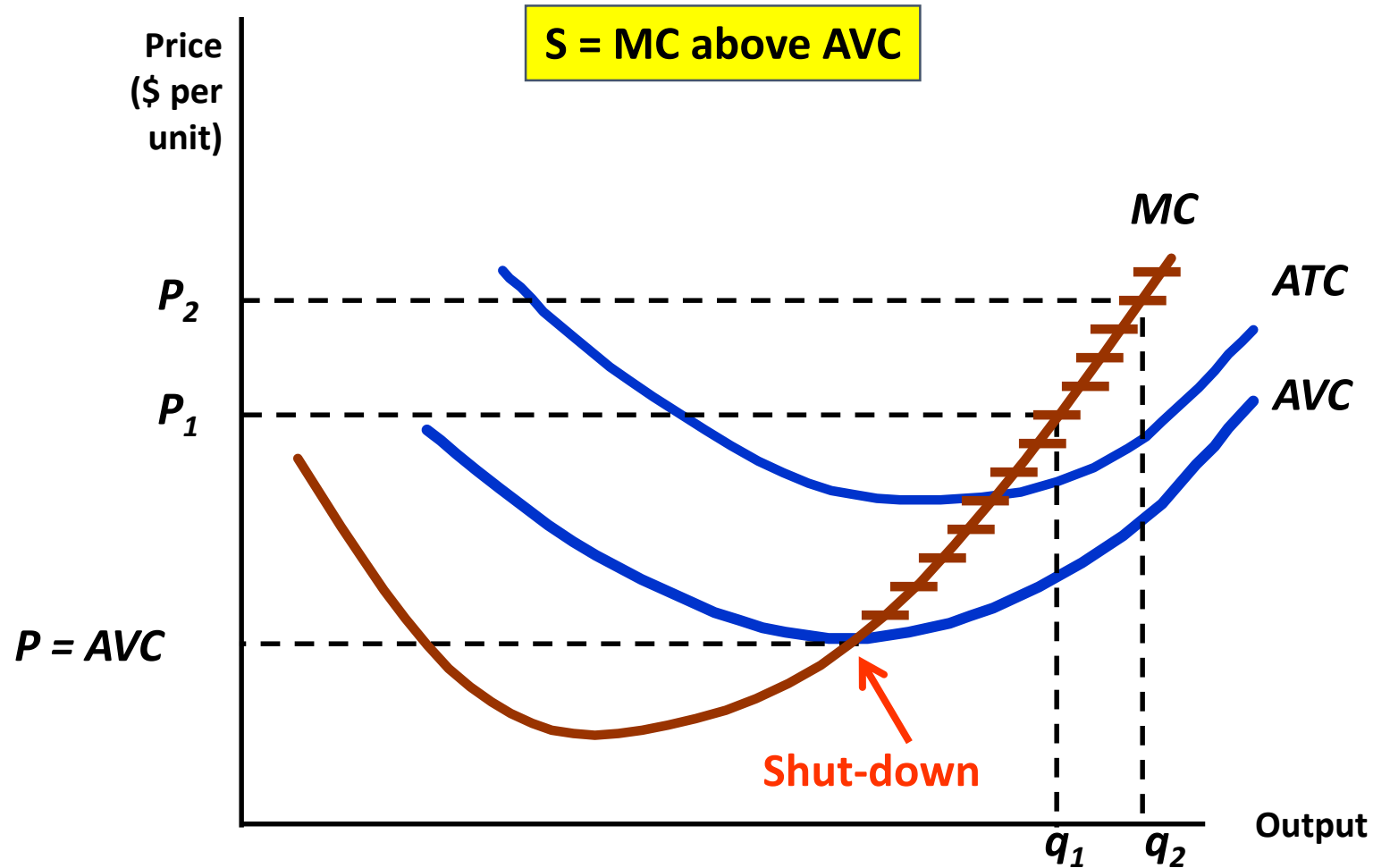

➤ What does the market supply curve look like?

- Suppose we have information on the supply behavior of all the producers currently in the market, i.e. we know the individual firms' supply curves.
- How do we derive the market supply curve?
- The market supply curve is the aggregation of the supply curves of all firms in the market.
- Thus we sum the quantities supplied by all firms at each possible price to get the market supply curve, i.e. we sum the firm supply curves horizontally (since we are aggregating quantities).
- [Refer to diagram drawn on board.]
- Does the short-run market supply curve for a perfectly competitive industry obey the Law of Supply? Why?

Market supply

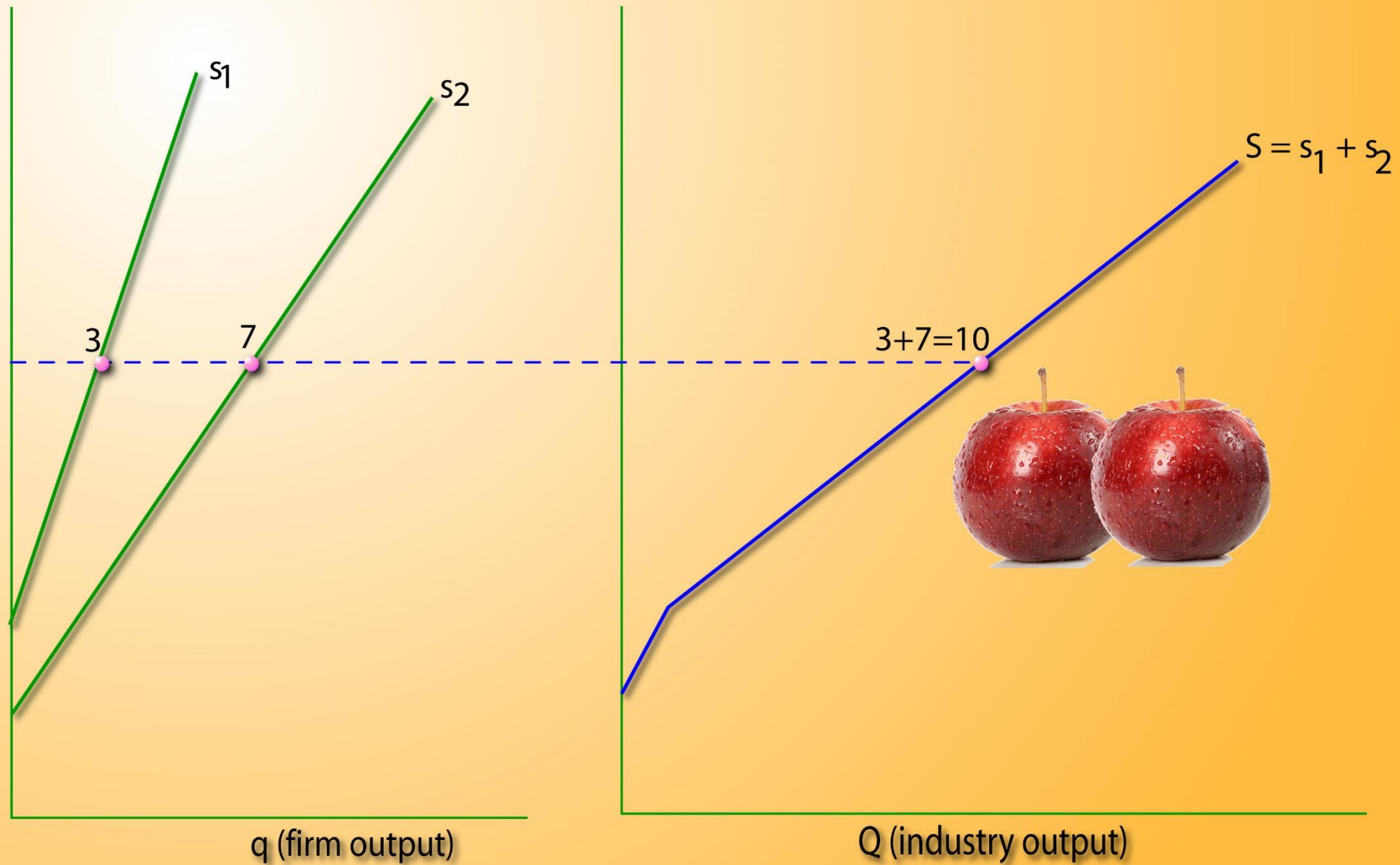

Short-run equilibrium in a perfectly competitive market

- A competitive market is in equilibrium in the short run when:
- Market price, P^* , clears the market, i.e. market quantity demanded equals quantity supplied, i.e. $Q_D = Q_S$.
- Each firm maximizes profit, producing q_i^* where $P^* = mc_i$.
- Market quantity supplied equals the aggregation of each firm's profit maximization decision: $Q_S = \sum_{i=1}^n q_i^*$
- Do firms make positive, negative, or zero economic profit?
- Depends on market price. [refer to diagrams on board]

FIGURE 12.8 Three Short-Run Outcomes for the Firm

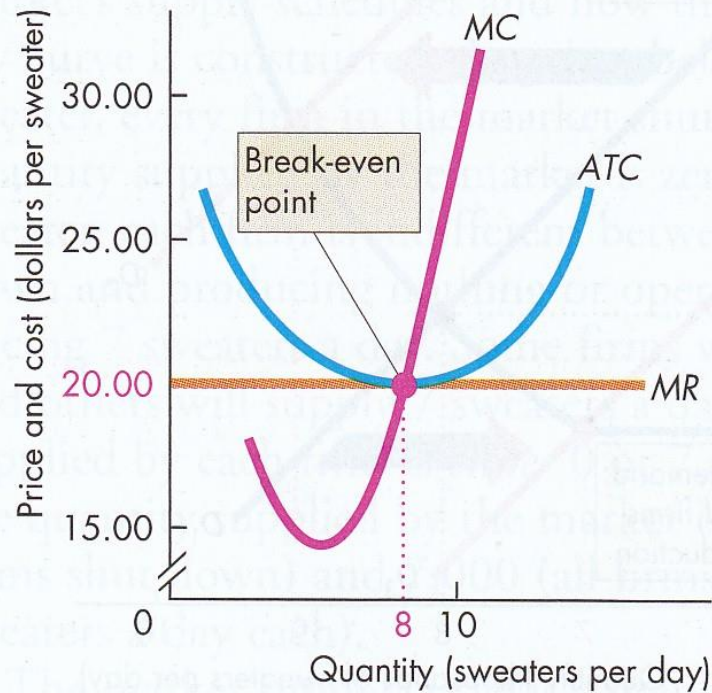

(a) Break even

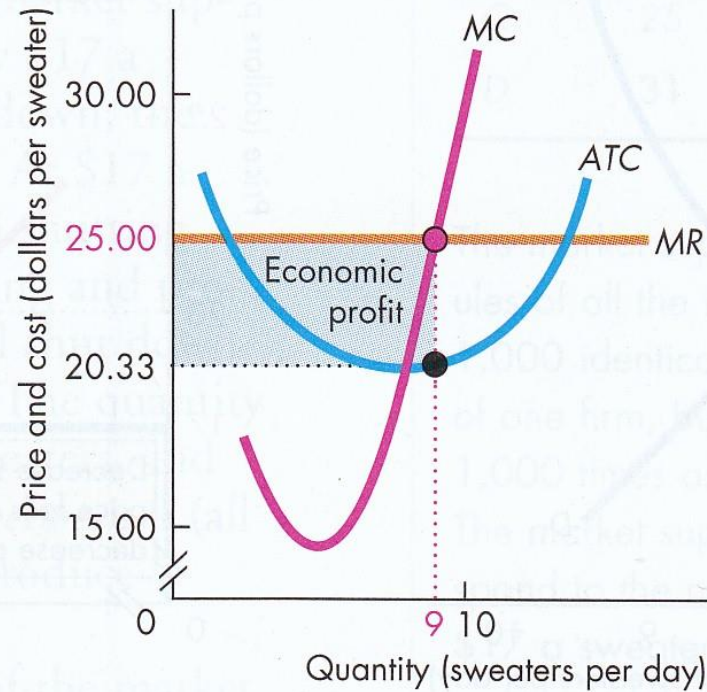

(b) Economic profit

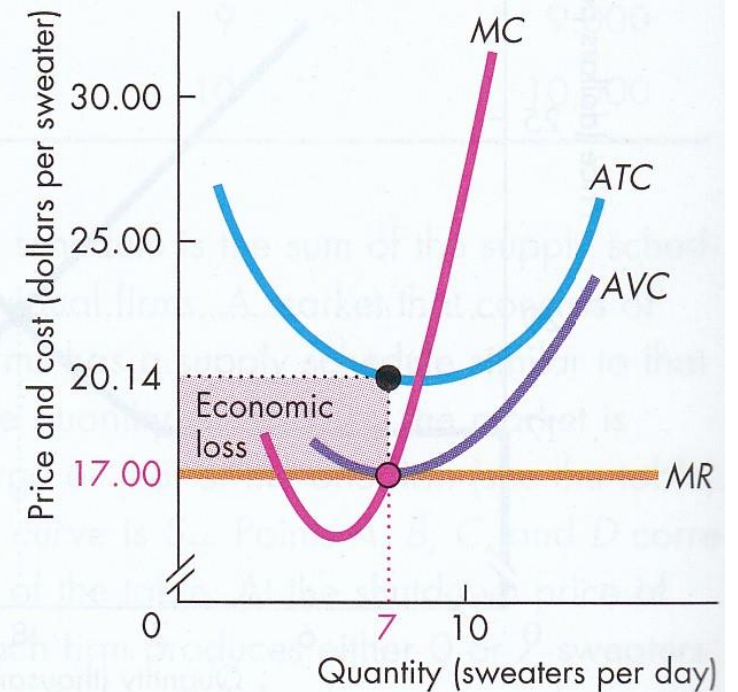

(c) Economic loss

In the short run, the firm might break even (make zero economic profit), make an economic profit, or incur an economic loss. In part (a), the price equals minimum average total cost. At the profit-maximizing output, the firm breaks even and makes zero economic profit. In part (b), the market price is \$25 a sweater. At the profit-maximizing

output, the price exceeds average total cost and the firm makes an economic profit equal to the area of the blue rectangle. In part (c), the market price is \$17 a sweater. At the profit-maximizing output, the price is below minimum average total cost and the firm incurs an economic loss equal to the area of the red rectangle.

Predicting the future: 1987

- Suppose it is 1987 and the market price of a 4-foot alligator is \$180. Alligator farmers are doing great, earning significant economic profits.
<http://ezproxy.uky.edu/login?url=http://search.proquest.com/docview/398158016?accountid=11836>
- [refer to diagrams on board].
- What do you think will happen as time passes? What does it mean that firms in the industry are earning positive economic profits?
- As entry occurs, what will happen to the market supply curve?
- What will happen to market price?
- After enough time passes for all adjustments to occur, what do you predict market price will be? How long will that take?

Predicting the future: 1997

- Suppose it is 1997 and the market price of a 4-foot alligator is \$100. Alligator farmers are struggling, suffering significant economic losses.
<http://ezproxy.uky.edu/login?url=http://search.proquest.com/docview/398605851?accountid=11836>
- [refer to diagrams on board].
- What do you think will happen as time passes? What does it mean that firms in the industry are earning negative economic profits?
- As exit occurs, what will happen to the market supply curve?
- What will happen to market price?
- After enough time passes for all adjustments to occur, what do you predict market price will be? How long will that take?

Long-run equilibrium in a perfectly competitive market

- A competitive market is in long-run equilibrium when:
- Market price P^* clears the market, i.e. market quantity demanded equals quantity supplied, i.e. $Q_D = Q_S$.
- Each firm maximizes profit, producing q_i^* where $P^* = mc_i$.
- Market quantity supplied equals the aggregation of each firm's profit maximization decision: $Q_S = \sum_{i=1}^n q_i^*$
- At P^* firms earn a normal economic return, i.e. zero economic profit.
- $P^* = \min \text{LRAC}$, i.e. firms produce the product as cheaply as is possible, given input prices and technology.

Working with the perfectly competitive model

- Market is in long-run equilibrium. Demand increases. What happens in the short run? What happens in the long run?
- Market is in long-run equilibrium. Demand decreases. What happens in the short run? What happens in the long run?
- Market is in long-run equilibrium. Technology improves, such that LRAC shifts downward. What happens in the short run? What happens in the long run?
- Market is in long-run equilibrium. The price of a key input increases, such that LRAC shifts upward. What happens in the short run? What happens in the long run?

Panel (a)
Market

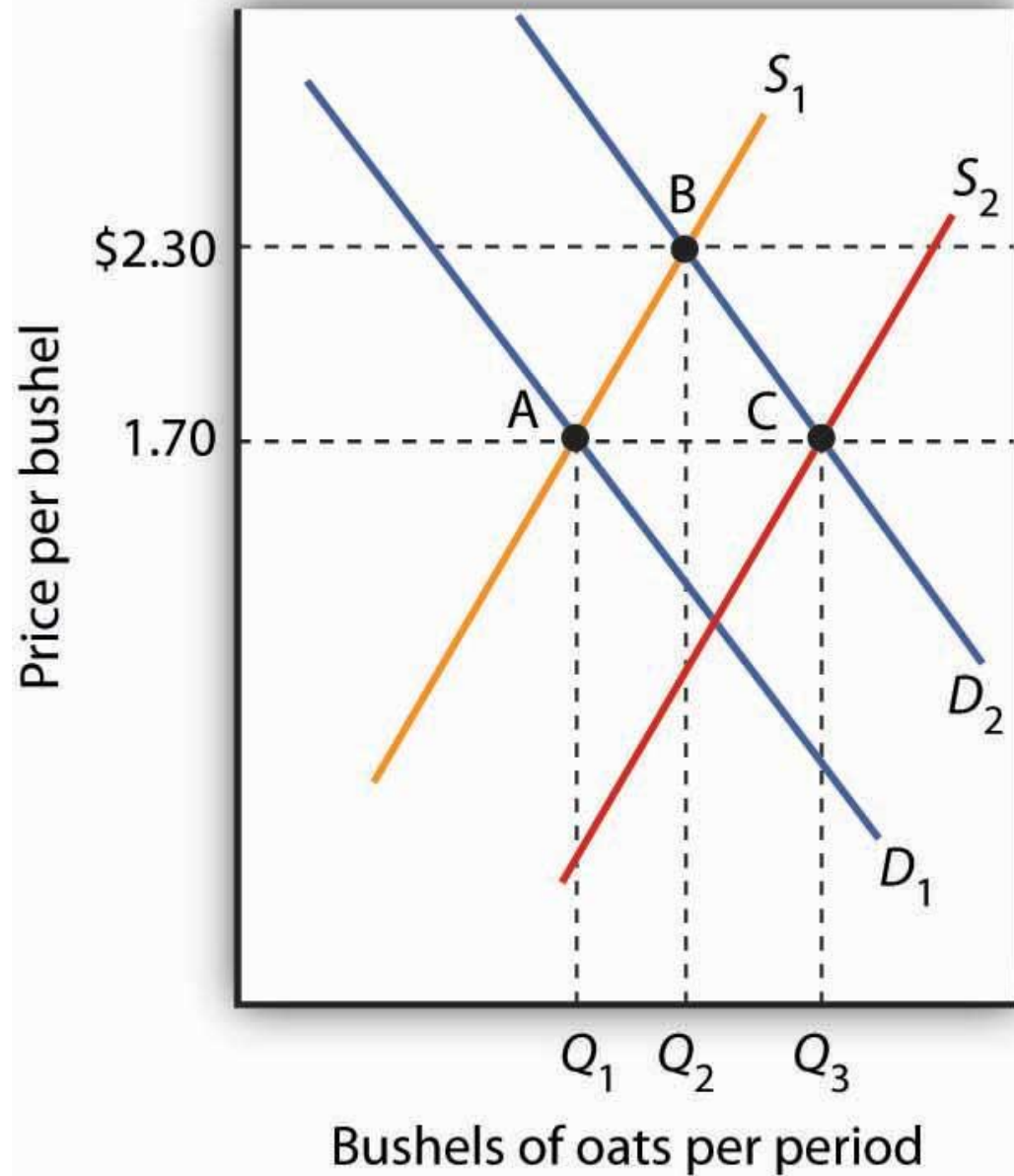

Panel (b)
One Firm

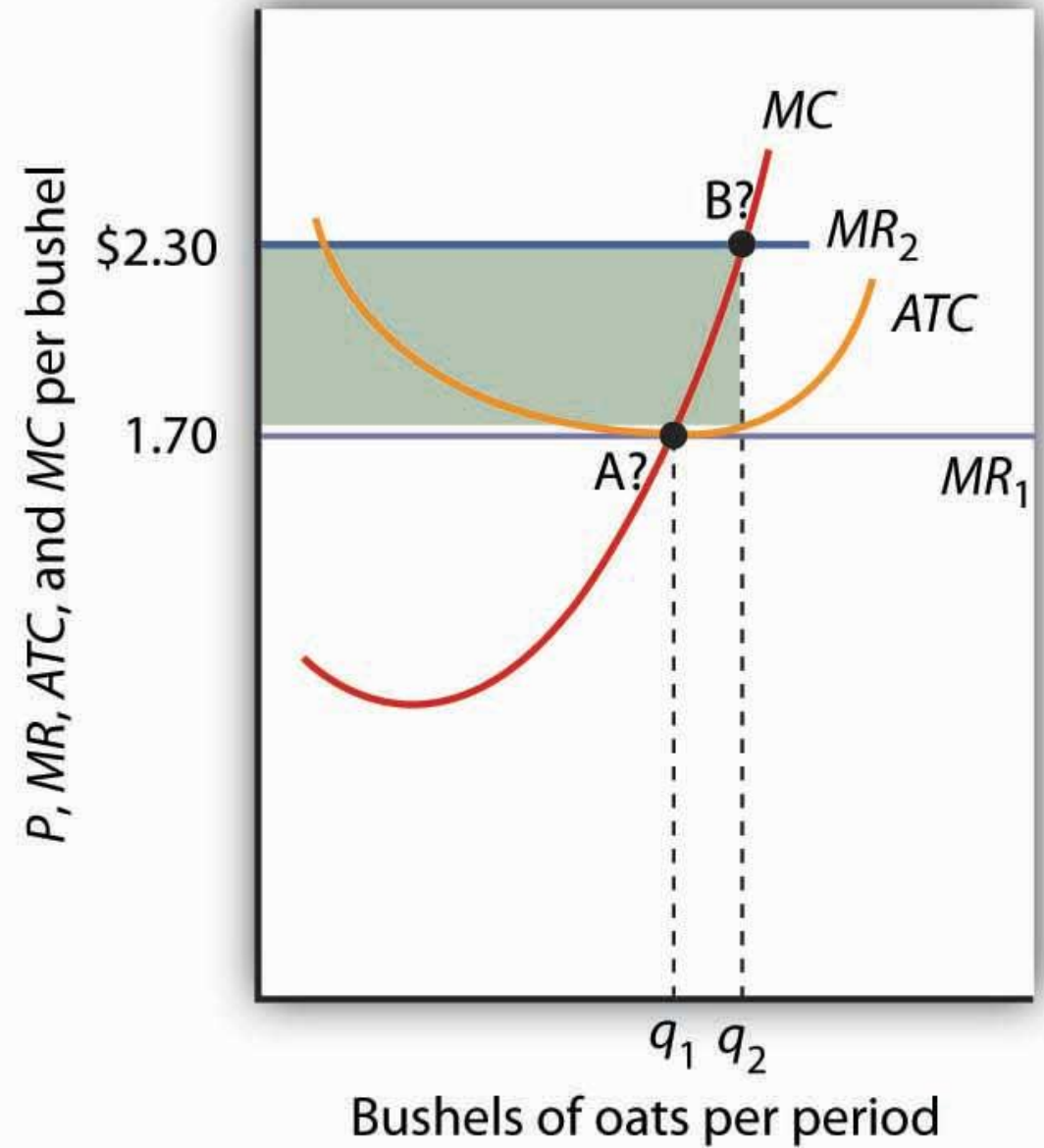

Choosing Output in the Long Run

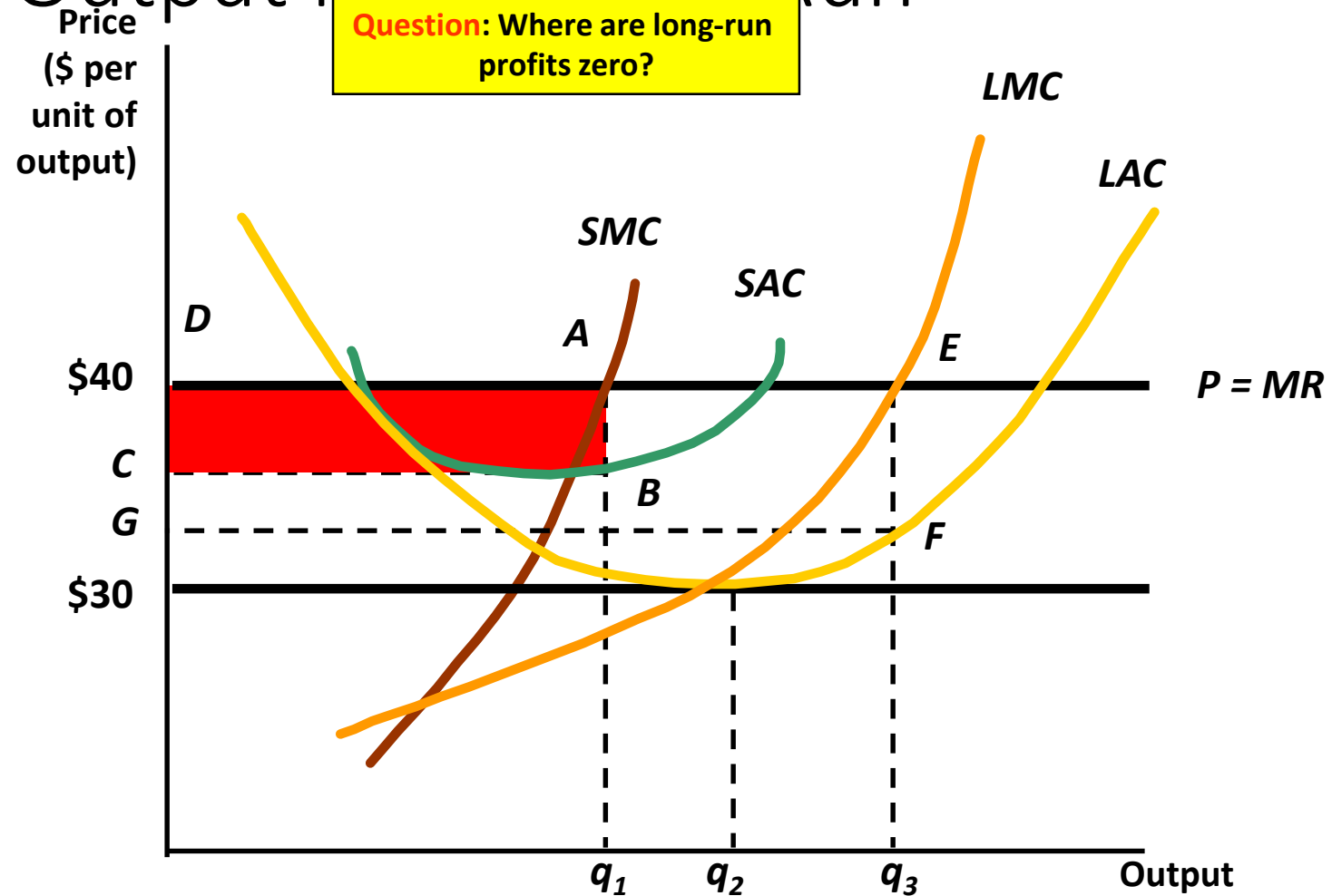

Long-Run Competitive Equilibrium

- Profit attracts firms
- Supply increases until profit = 0

